

THE CUTTING

MASONRY

PAGE

42 **SDS PLUS BULK 10 PACKS**

42 **SDS PLUS SETS**



IGEDGE

alpha

PAGE

36 MASONRY DRILL BITS



38 COUNTERSINK DEPTH GAUGE



39 UNIDRE MASONRY STRAIGHT



39 UNIDRE MASONRY HEX



40 SDS PLUS



42 SDS PLUS BULK 10 PACKS



43 SDS XR3



44 ZENTRO 4-CUTTER PLUS



45 ZENTRO 4-CUTTER MAX



46 HEX SHANK 13MM ZENTRO



48 CORE CUTTERS



50 CHISELS



51 SDS MAX TO PLUS ADAPTOR



51 DRECONNECT ADAPTOR



MASONRYPROBITS

professional quality, suitable for rotary and impact drilling



measure standard		style		material		alpha	
METRIC		STRAIGHT SHANK MASONRY		CARBIDE TIP			
Drill Dia.	Code	OAL	FL.			Price	Pack
mm		mm	mm			each	qty
MASONRY PRO DRILL BITS							
3	MA030070G	70	40				1
3	MA030070G10	70	40		Industrial 10 pack		10
3.5	MA035080G	80	45				1
4	MA040085G	85	50				1
5	MA050085G	85	50				1
5	MA050150G	150	90				1
5.5	MA055085G	85	50				1
5.5	MA055150G	150	90				1
6	MA060100G	100	60				1
6	MA060150G	150	90				1
6.5	MA065100G	100	60				1
6.5	MA065150G	150	90				1
7	MA070150G	150	90				1
8	MA080120G	120	80				1
8	MA080200G	200	150				1
9	MA090120G	120	80				1
10	MA100120G	120	80				1
10	MA100200G	200	150				1
12	MA120150G	150	90				1
12	MA120400G	400	350				1
13	MA130150G	150	90				1
14	MA140150G	150	90				1
14	MA140400G	400	350				1
16	MA160160G	160	100				1
16	MA160400G	400	350				1
18	MA180160G	160	100				1
20	MA200160G	160	100				1
SUPPLIED IN RETAIL HANG PACKS							



brick



tile



ceramic



concrete

MASONRY DRILL BITS

suitable for rotary and impact drilling



measure standard		style		material			alpha	
METRIC		STRAIGHT SHANK MASONRY		CARBIDE TIP				
Drill Dia.	Code	OAL	FL				Price	Pack
mm		mm	mm				each	qty
MASONRY DRILL BITS								
3	MA030065	65	32					1
3.5	MA035075	75	37					1
4	MA040075	75	37					1
4.5	MA045065	65	37					1
4.5	MA045150	150	100					1
5	MA050085	85	45					1
5	MA050150	150	90					1
5.5	MA055085	85	45					1
5.5	MA055150	150	90					1
6	MA060100	100	55					1
6	MA060150	150	90					1
6.5	MA065100	100	55					1
6.5	MA065150	150	90					1
6.5	MA065300	300	200					1
7	MA070100	100	55					1
8	MA080120	120	70					1
8	MA080150	150	90					1
8	MA080300	300	200					1
10	MA100120	120	70					1
10	MA100150	150	90					1
10	MA100400	400	267					1
11	MA110150	150	90					1
12	MA120150	150	90					1
12	MA120400	400	267					1
13	MA130150	150	90					1
14	MA140210	210	150					1
16	MA160150	150	90					1
16	MA160400	400	267					1
SUPPLIED IN INDUSTRIAL HANG PACKS								

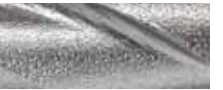

MASONRY DRILL BITS SHALLOW

ideal for drilling and counter-sinking fibre cement and compressed fibre cement sheeting



MASONRY DRILL BITS DEEP



measure standard
METRIC

style
COUNTER SINK DEPTH GAUGE

material
CARBIDE TIP

alpha



shallow hole



deep hole

Dia. mm	Code	Depth mm					Price each	Pack qty
SHALLOW CUT MASONRY DRILL BITS WITH COUNTER SINK DEPTH GAUGE								
5	MADG0509	9	Shallow					1
6	MADG0609	9	Shallow					1
SUPPLIED CARDED								
Dia. mm	Code	Depth mm					Price each	Pack qty
DEEP CUT MASONRY DRILL BITS WITH COUNTER SINK DEPTH GAUGE								
5	MADG0518	18	Deep					1
6	MADG0618	18	Deep					1

SUPPLIED CARDED

blue board / fibre cement

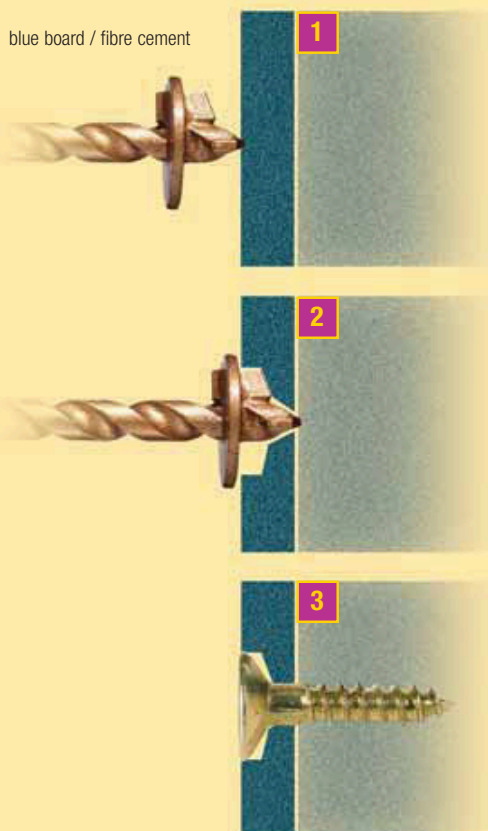

UNIDRE MASONRY STRAIGHT SHANK

For drilling wood, metal, plastic, brick, tiles, ceramics, plasterboard and aerated concrete



UNIDRE MASONRY HEX SHANK

For drilling wood, metal, plastic, brick, tiles, ceramics, plasterboard and aerated concrete, fits 1/4" bit holder



1/4" hex

measure standard	style	material
METRIC	MULTI-PURPOSE STRAIGHT SHANK	SHARPENED CARBIDE TIP



Dia. mm	Code	OAL mm	FL mm	Price each	Pack qty
STRAIGHT SHANK MASONRY DRILL					
3.0	UNI030070	70	40		26
4.0	UNI040085	85	50		26
5.0	UNI050085	85	50		26
6.0	UNI060100	100	60		26
6.5	UNI065100	100	60		26
8.0	UNI080120	120	80		26
10.0	UNI100120	120	80		26
12.0	UNI120150	150	90		26
SUPPLIED IN RETAIL HANG PACK					



measure standard	style	material
METRIC	MULTI-PURPOSE HEX SHANK	SHARPENED CARBIDE TIP

Dia. mm	Code	OAL mm	FL mm	Price each	Pack qty
HEX SHANK MASONRY DRILL					
3.0	UNIHEX30	95	40		26
4.0	UNIHEX40	105	50		26
5.0	UNIHEX50	105	50		26
6.0	UNIHEX60	115	60		26
6.5	UNIHEX65	115	60		26
8.0	UNIHEX80	135	80		26
SUPPLIED IN RETAIL HANG PACK					



measure standard	style	material
METRIC	MULTI-PURPOSE HEX SHANK SET	SHARPENED CARBIDE TIP

Dia. mm	Code	Price each	Pack qty
HEX SHANK MASONRY DRILL SET			
3-8	UNIHEXSET5	5 Piece UniDre 1/4 Hex Masonry Drill Set 3, 5, 6, 6.5, 8mm	1

SDSPLUSDRILLBITS



measure standard		style		material			alpha	
METRIC		SDS PLUS		CARBIDE TIP				
Dia.	Code	OAL	FL				Price	Box
mm		mm	mm				each	qty
SDS PLUS								
4	SP040110G	110	50					25
4	SP040160G	160	100					25
5	SP050110G	110	50					25
5	SP050160G	160	100					25
5	SP050210G	210	150					25
5.5	SP055110G	110	50					25
5.5	SP055160G	160	100					25
5.5	SP055210G	210	150					25
5.5	SP055310G	310	250					20
6	SP060110G	110	50					25
6	SP060160G	160	100					25
6	SP060210G	210	150					25
6	SP060310G	310	250					20
6	SP060460G	460	400					25
6.5	SP065110G	110	50					25
6.5	SP065160G	160	100					25
6.5	SP065210G	210	150					25
6.5	SP065260G	260	200					25
6.5	SP065310G	310	250					25
7	SP070160G	160	100					25
7	SP070250G	250	200					25
7	SP070450G	450	400					20
8	SP080110G	110	50					25
8	SP080160G	160	100					25
8	SP080210G	210	150					25
8	SP080260G	260	200					25
8	SP080310G	310	250					20
8	SP080460G	460	400					20
8	SP080600G	600	550					20
9	SP090210G	210	150					25
10	SP100110G	110	50					25
10	SP100160G	160	100					25
10	SP100210G	210	150					25
10	SP100260G	260	200					25
10	SP100350G	350	300					25
10	SP100450G	450	400					20
10	SP100600G	600	550					20
10	SP1001000G	1000	950					20
11	SP110260G	260	200					20
12	SP120160G	160	100					20
12	SP120210G	210	150					20

centering chisel head with multi-flute spiral for maximum drilling capacity



Easy centring spot drilling



Dynamic, chisel-shaped head design



Cross-section of Alpha SDS Flute



Standard competition cross-section



measure standard	style	material	alpha	
METRIC	SDS PLUS	CARBIDE TIP		

Dia. mm	Code	OAL mm	FL mm	Price each	Box qty
SDS PLUS					
12	SP120260G	260	200		20
12	SP120360G	360	300		10
12	SP120450G	450	400		20
12	SP120600G	600	550		20
12	SP1201000G	1000	950		20
13	SP130160G	160	100		20
13	SP130210G	210	150		20
13	SP130310G	310	250		10
13	SP130450G	450	400		10
14	SP140260G	260	200		20
14	SP140450G	450	400		10
14	SP140600G	600	550		10
14	SP1401000G	1000	950		10
15	SP150260G	260	200		10
15	SP150450G	450	400		10
16	SP160160G	160	100		10
16	SP160210G	210	150		10
16	SP160260G	260	200		10
16	SP160310G	310	250		10
16	SP160450G	450	400		10
16	SP160600G	600	550		10
16	SP160800G	800	750		10
18	SP180200G	200	150		10
18	SP180300G	300	250		10
18	SP180450G	450	400		10
18	SP180600G	600	550		10
20	SP200200G	200	150		10
20	SP200300G	300	250		10
20	SP200450G	450	400		10
20	SP200600G	600	550		10
22	SP220250G	250	200		10
22	SP220450G	450	400		10
22	SP220600G	600	550		10
23	SP230450G	450	400		10
24	SP240250G	250	200		10
24	SP240450G	450	400		10
25	SP250250G	250	200		10
25	SP250450G	450	400		10
25	SP250600G	600	550		10
26	SP260250G	250	200		10
26	SP260450G	450	400		10



SDSPLUSDRILLBITS

centering chisel head with multi-flute spiral for maximum drilling capacity



measure standard		style		material		alpha	
METRIC		SDS PLUS		CARBIDE TIP			
Dia.	Code	OAL	FL			Price	Pack
mm		mm	mm			each	qty
SDS PLUS BULK 10 PACKS							
5	SP050110G-10	110	50				10
5	SP050160G-10	160	100				10
5.5	SP055110G-10	110	50				10
5.5	SP055160G-10	160	100				10
6	SP060110G-10	110	50				10
6	SP060160G-10	160	100				10
6.5	SP065110G-10	110	50				10
6.5	SP065160G-10	160	100				10
8	SP080160G-10	160	100				10
10	SP100160G-10	160	100				10
10	SP100210G-10	210	150				10
12	SP120160G-10	160	100				10
12	SP120210G-10	210	150				10
14	SP140260G-10	260	200				10
16	SP160160G-10	160	100				10
SDS PLUS 5 & 7 PIECE SETS							
Dia.	Code	Description				Price	Pack
mm						each	qty
5-10	SPSET5	5 Piece SDS Plus Masonry Drill Set x 160mm 5, 6, 6.5, 8, 10mm					1
5-12	SPSET5-D	5 Piece SDS Plus Masonry Drill Set x 160mm 5, 6.5, 8, 10, 12mm					1
5-12	SPSET7	7 Piece SDS Plus Masonry Drill Set x 160mm 5, 5.5, 6, 6.5, 8, 10, 12mm					1



SDSXR3DRILLBITS

suits SDS Plus and Ramset® R-3



measure standard		style		material		alpha	
METRIC		SDS XR3		CARBIDE TIP			
Dia.	Code	OAL	FL			Price	Pack
mm		mm	mm			each	qty
SDS XR3							
5	SR050110G	110	50				25
5	SR050160G	160	100				25
5.5	SR055110G	110	50				25
5.5	SR055160G	160	100				25
6	SR060110G	110	50				25
6	SR060160G	160	100				25
6	SR060210G	210	150				25
6.5	SR065110G	110	50				25
6.5	SR065160G	160	100				25
6.5	SR065210G	210	150				25
8	SR080110G	110	50				25
8	SR080160G	160	100				25
8	SR080210G	210	150				25
10	SR100160G	160	100				25
10	SR100210G	210	150				25
12	SR120160G	160	100				20
12	SR120210G	210	150				20
14	SR140260G	260	200				20
16	SR160310G	310	250				10
18	SR180310G	310	250				10
20	SR200310G	310	250				10
22	SR220450G	450	400				10
26	SR260450G	450	400				10

Ramset and R3 are trademarks of ITW Corporation and have no connection with Alpha



Easy centring spot drilling



Dynamic, chisel-shaped head design

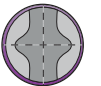

Cross-section of Alpha SDS Flute

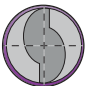

Standard competition cross-section

SDSPLUSZENTRO4-CUTTERDRILLBITS

dynamic drilling ability with secondary cutters protecting the drill bit in the event of reinforcement collision



measure standard		style		material				alpha	
METRIC		SDS PLUS ZENTRO 4-CUTTER		CARBIDE TIP x4					
Dia.	Code	OAL	FL				Price	Pack	
mm		mm	mm				each	qty	
SDS PLUS ZENTRO 4-CUTTER									
5	SPZ050110	110	50					25	
5	SPZ050160	160	100					25	
5.5	SPZ055110	110	50					25	
5.5	SPZ055160	160	100					25	
6	SPZ060110	110	50					25	
6	SPZ060160	160	100					25	
6	SPZ060210	210	150					25	
6.5	SPZ065160	160	100					25	
6.5	SPZ065210	210	150					25	
8	SPZ080160	160	100					25	
8	SPZ080210	210	150					25	
10	SPZ100160	160	100					25	
10	SPZ100210	210	150					25	
12	SPZ120160	160	100					20	
12	SPZ120210	210	150					20	
12	SPZ120310	310	250					20	
14	SPZ140260	260	200					20	
16	SPZ160250	250	200					1	
16	SPZ160450	450	400					1	
18	SPZ180250	250	200					1	
18	SPZ180450	450	400					1	
20	SPZ200250	250	200					1	
20	SPZ200450	450	400					1	
22	SPZ220250	250	200					1	
22	SPZ220450	450	400					1	
24	SPZ240250	250	200					1	
24	SPZ240450	450	400					1	
25	SPZ250250	250	200					1	
25	SPZ250450	450	400					1	
28	SPZ280250	250	200					1	
28	SPZ280450	450	400					1	
30	SPZ300250	250	200					1	
30	SPZ300450	450	400					1	
32	SPZ320450	450	400					1	



SDS MAX MASONRY DRILL BITS

Max Performance, German quality and design
 Secondary cutters protect the drill bit in the event of reinforcement collision
 Maximum energy transfer, Excellent performance, Long Life SDS MAX



measure standard	style	material	
METRIC	SDS MAX ZENTRO 4-CUTTER	CARBIDE TIP x4	alpha

Dia.	Code	OAL	FL				Price	Pack
mm		mm	mm				each	qty
SDS MAX MASONRY DRILL BITS								
*12	SX12340	340	200					1
*12	SX12540	540	400					1
*14	SX14340	340	200					1
*14	SX14540	540	400					1
*14	SX14920	920	800					1
16	SXZ16340	340	200					1
16	SXZ16540	540	400					1
16	SXZ16920	920	800					1
18	SXZ18340	340	200					1
18	SXZ18540	540	400					1
18	SXZ18920	920	800					1
20	SXZ20320	320	200					1
20	SXZ20520	520	400					1
20	SXZ20920	920	800					1
22	SXZ22320	320	200					1
22	SXZ22520	520	400					1
22	SXZ22920	920	800					1
24	SXZ24320	320	200					1
24	SXZ24520	520	400					1
25	SXZ25320	320	200					1
25	SXZ25520	520	400					1
25	SXZ25920	920	800					1
26	SXZ26520	520	400					1
28	SXZ28370	370	250					1
28	SXZ28570	570	450					1
28	SXZ28920	920	800					1
30	SXZ30370	370	250					1
30	SXZ30570	570	450					1
32	SXZ32370	370	250					1
32	SXZ32570	570	450					1
32	SXZ32920	920	800					1
35	SXZ35570	570	450					1
35	SXZ35920	920	800					1
37	SXZ37570	570	450					1
38	SXZ38370	370	250					1
38	SXZ38570	570	450					1
40	SXZ40370	370	250					1
40	SXZ40570	570	450					1
40	SXZ40920	920	800					1
45	SXZ45570	570	450					1
50	SXZ50570	570	450					1
52	SXZ52570	570	450					1



* the 12-14mm diameter drills are manufactured as 2-cutters

HEXSHANK13MMDRILLBITS



13mm



measure standard	style	material	alpha
METRIC	13mm HEX SHANK ZENTRO	CARBIDE TIP x4	

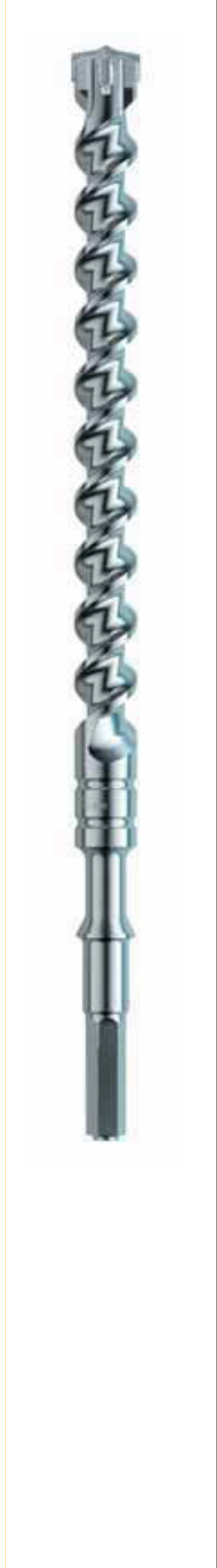

Dia. mm	Code	OAL mm	FL mm				Price each	Pack qty
HEX SHANK 13MM ZENTRO 4-CUTTER								
16	MHZ16280	280	130					1
18	MHZ18280	280	130					1
18	MHZ18400	400	250					1
20	MHZ20280	280	130					1
20	MHZ20400	400	250					1
22	MHZ22280	280	130					1
22	MHZ22400	400	250					1
25	MHZ25400	400	250					1

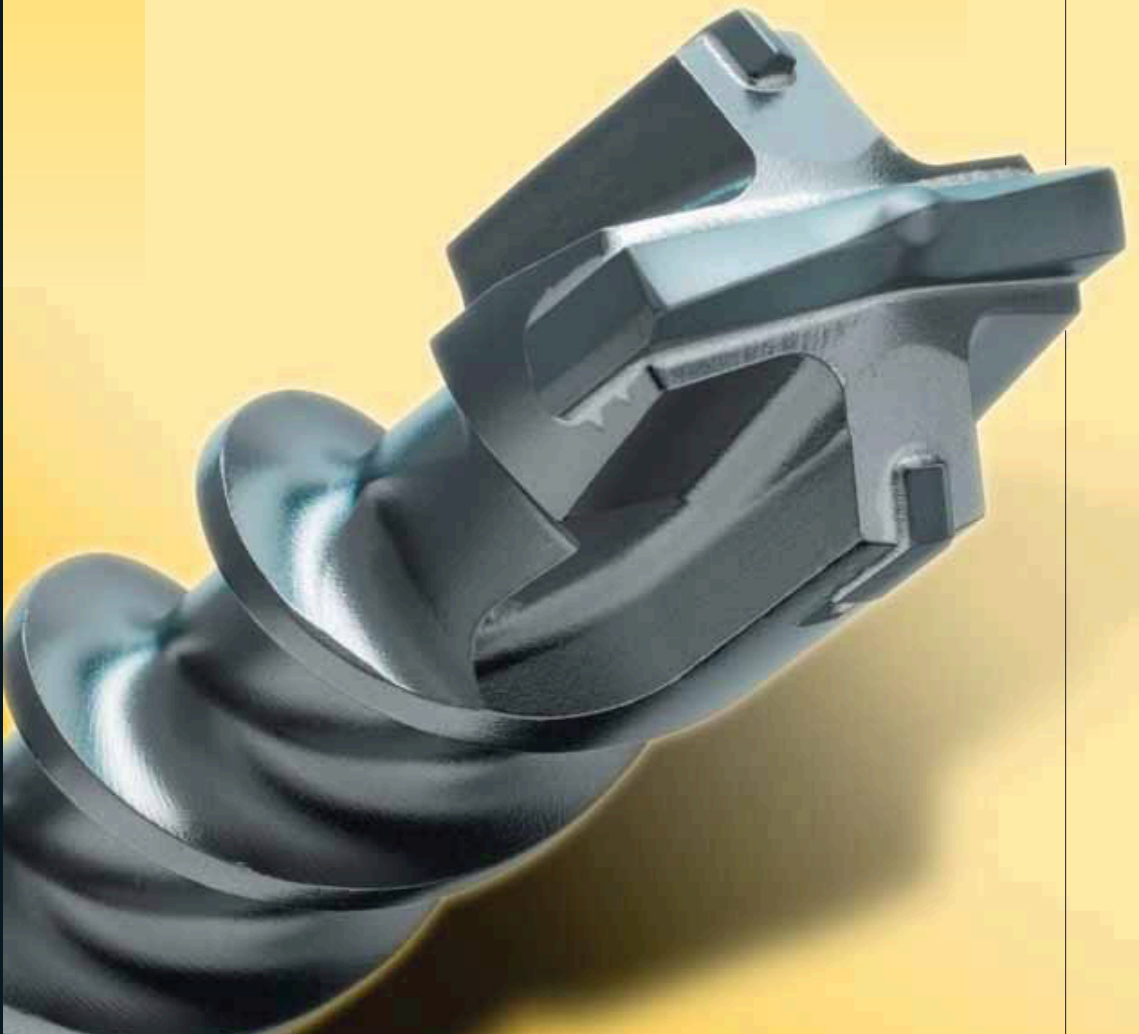



The one-piece, solid carbide tip and patented reinforcing chamfering ensure low vibration and optimum drilling performance when drilling into reinforcing steel



Thanks to optimum 4 x 90° symmetry, all four carbide cutting edges function evenly and do not seize up on hitting reinforcing steel



Lateral support and maximum possible area of the interface between the carbide and steel body compensate for torsional forces



Centring tip for straight forward spot drilling with pinpoint accuracy



Four symmetrically functioning spiral ridges ensure low, uniform flute wear



Optimised flute core strength ensures low vibration drilling performance and exceptional fracture resistance

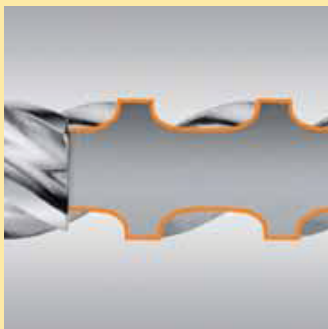

The high-volume flute geometry ensures the optimum removal of drilling dust



4 Cutter head prevents seizing when drilling through reinforcing steel

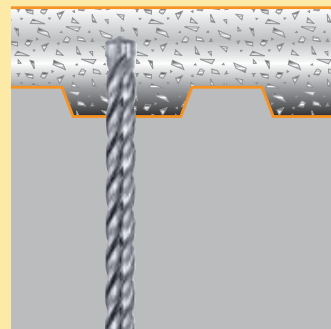

Penetrates through steel deck plate eg Bondek® and concrete in one easy process

HOLLOWCOREBITS



SDSPLUSADAPTOR



CENTREPILOTDRILL



measure standard	style	material	alpha		
METRIC	HOLLOW CORE	CARBIDE TIP			
Core Dia mm	Code	OAL mm	Description	Price each	Pack qty
HOLLOW CORE BITS					
30	HCB30X58	58	30mm Hollow Core Bit		1
40	HCB40X58	58	40mm Hollow Core Bit		1
45	HCB45X58	58	45mm Hollow Core Bit		1
50	HCB50X58	58	50mm Hollow Core Bit		1
65	HCB65X50	50	65mm Hollow Core Bit		1
80	HCB80X50	50	80mm Hollow Core Bit		1
90	HCB90X50	50	90mm Hollow Core Bit		1
100	HCB100X50	50	100mm Hollow Core Bit		1
110	HCB110X50	50	110mm Hollow Core Bit		1
Code	OAL mm	Description	Price each	Pack qty	
SDS PLUS SHANK ADAPTOR					
	SPADP105	105	SDS Plus Shank Adaptor x 105mm		1
	SPADP220	220	SDS Plus Shank Adaptor x 220mm		1
	SPADP370	370	SDS Plus Shank Adaptor x 370mm		1
Drill Dia mm	Code	OAL mm	Description	Price each	Pack qty
CENTRING PILOT DRILL FOR HOLLOW CORE DRILLS					
8	CDP080120	120	Centring Pilot Drill 8mm x 120mm		1

SDS-MAXCORECUTTER

For use in concrete, masonry and natural stone.

The Alpha Concrete Core Cutter is the modern tool for professional users. The one piece core cutter specially developed for the latest generation of powerful rotary hammers guarantees efficient drilling and superior life.

Unique head design presents decisive advantages!

accurate spot drilling

fast penetration rate thanks to chisel-shaped carbide teeth

additional raker teeth to hollow out the entire core diameter, no chiselling out necessary

high volume flutes for fast removal of dust and debris

long life expectancy

low weight, reduced vibration

one-piece design transfers hammer energy to tool without damping losses

straight, circular holes with flat base

significantly improved performance when drilling steel reinforcement

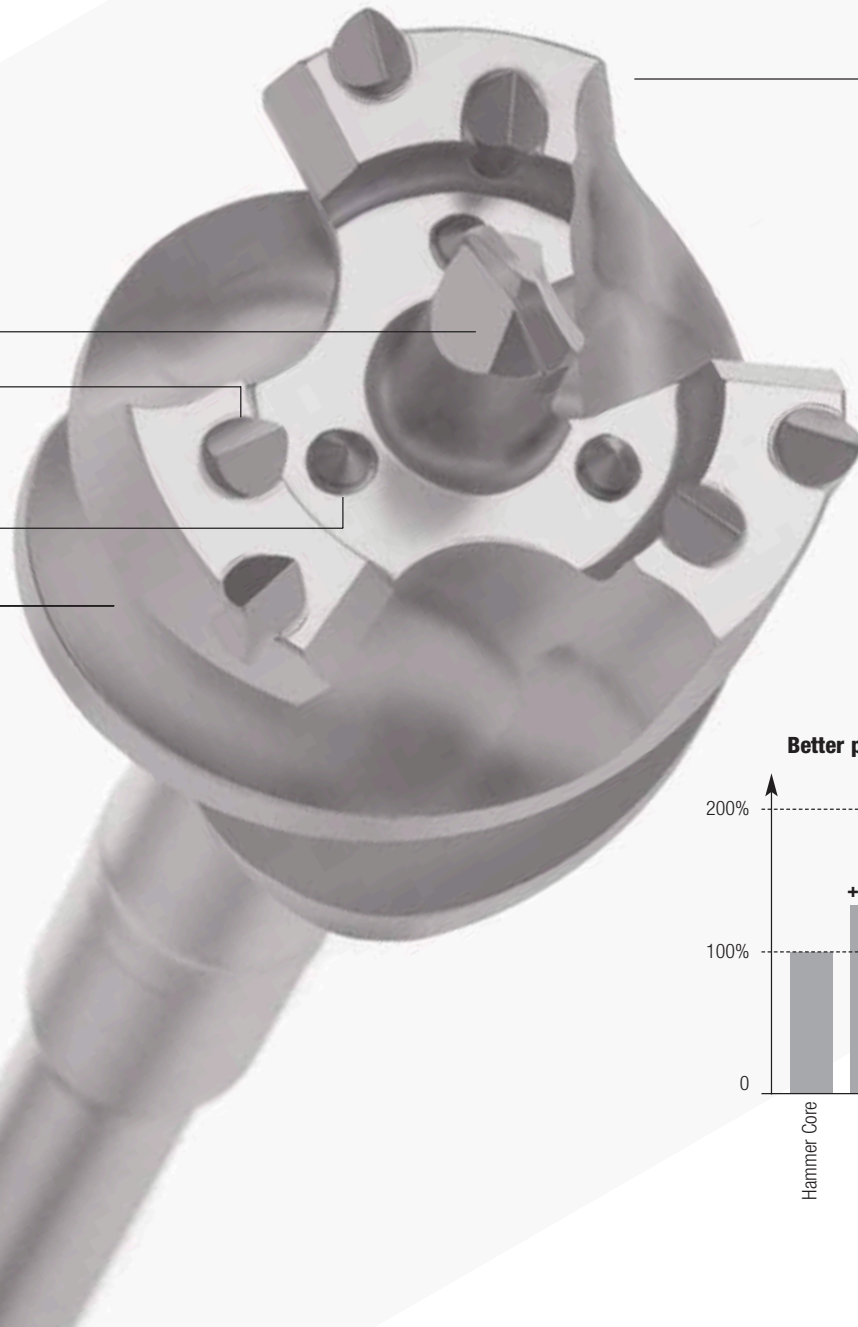

Better performance

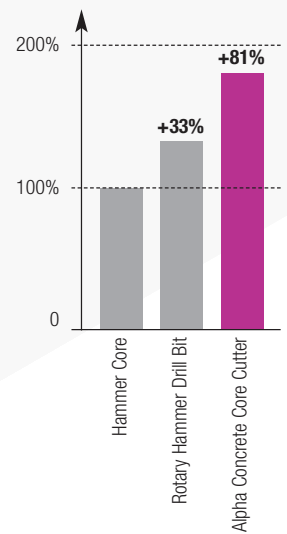

measure standard

METRIC

style

CONCRETE CORE CUTTER

material

CARBIDE TIP

alpha

Core Dia mm	Code	OAL mm	Description	Price each	Pack qty
CONCRETE CORE CUTTER WITH SDS-MAX SHANK					
40	CCC40x310	310	One piece tunnel drill		1
40	CCC40x550	550	One piece tunnel drill		1
45	CCC45x310	310	One piece tunnel drill		1
45	CCC45x550	550	One piece tunnel drill		1
55	CCC55x310	310	One piece tunnel drill		1
55	CCC55x550	550	One piece tunnel drill		1
65	CCC65x310	310	One piece tunnel drill		1
65	CCC65x550	550	One piece tunnel drill		1
80	CCC80x310	310	One piece tunnel drill		1
80	CCC80x550	550	One piece tunnel drill		1



SDSCHISELSPONTED

Alpha SDS MAX and SDS PLUS fitments are available



SDSCHISELSFLAT



SDSCHISELSPADE



SDSCHISELSHOLLOW



	measure standard		style				alpha
	METRIC		SDS MAX & SDS PLUS				
SDS Chisel	Code	Width mm	Length mm	Description	Price each	Pack qty	
SDS CHISELS							
PLUS	SPPC250		250	SDS Plus Pointed Chisel		50	
PLUS	SPFC20250	20	250	SDS Plus Flat Chisel		50	
PLUS	SPSC40250	40	250	SDS Plus Spade Chisel		20	
PLUS	SPHOL250	22	250	SDS Plus Hollow Chisel		10	
MAX	SXPC280		280	SDS Max Pointed Chisel		25	
MAX	SXFC25280	25	280	SDS Max Flat Chisel		30	
MAX	SXSC50400	50	400	SDS Max Spade Chisel		15	
MAX	SXHOL300	26	300	SDS Max Hollow Chisel		10	



SDS MAX TO SDS PLUS ADAPTOR

get the maximum out of your rotary hammer with the Alpha SDS MAX to SDS PLUS Adapter



DRECONNECT ADAPTOR SYSTEM

make your rotary hammer so much more versatile
Now the full range of SDS Max accessories can fit almost any rotary hammer on the market



select the extension to suit your rotary hammer

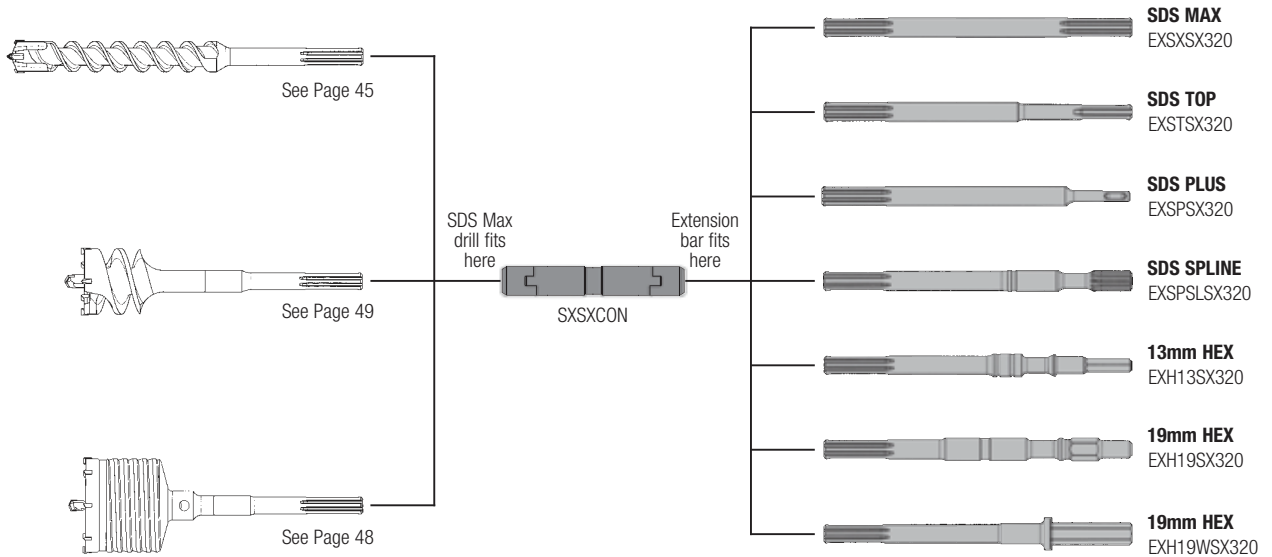

longer extensions are available up to 1100mm for extra deep drilling

measure standard		style			
METRIC		CONNECT ADAPTOR		alpha	
SDS	Code	OAL mm	Description	Price each	Pack qty
SDS MAX ADAPTOR					
MAX	SX-SPADP	400	SDS Max to SDS Plus Adaptor		1
DRECONNECT ADAPTOR SYSTEM					
30	SXSXCON	190	DreConnect Adapter 30 x 190mm		1
DRECONNECT EXTENSIONS					
	EXSXSX320	320	SDS Max to SDS MAX Extension		1
			For the other extensions to suits your tool - Please enquire		